



flawless fusion with infinite possibilities

SIFAM
F I B R E O P T I C S

High Reliability 3dB splitter



High Reliability (hi-rel) Components are deployed in environments such as undersea and space, where the costs of component replacement are prohibitive. SIFAM is established as a supplier of these components to major undersea equipment manufacturers.

SIFAM's hi-rel capability is built upon the foundation of a long established history of manufacturing very reliable terrestrial components. Full facilities are available to carry out customer-specific hi-rel qualification programmes, which can consist of accelerated ageing and Weibull analysis.

Manufacturing is carried out on specially-developed workstations. Advanced fibre management, in-process screening and customer-specific validation tests are implemented, to further enhance component reliability.

Component types available include fused fibre couplers, tap couplers and wavelength division multiplexers. The ultra-low loss of SIFAM fused fibre components helps to promote low noise figure and improved system margin in undersea transmission systems.

Components are supplied in regular (bare fibre) or custom housings, depending on the installation environment.

Please contact us to discuss your specific requirements.

Key Features:

- Established hi-rel supplier
- High performance
- Full qualification facilities available
- Advanced in-process testing
- Ultra-low loss fused components
- Choice of housings
- Design standard 0.1FITs (failure in 1 billion field hours)

Applications:

- Undersea equipment
- Terminal equipment
- Space
- Defence and Avionic

Compliance:

- Customer specific



SIFAM Fibre Optics Ltd
Broomhill Way, Torquay
Devon TQ2 7QL
England



Certificate No. 0962231

As part of our policy of continuous product improvement we reserve the right to change specifications at any time
PEC 0136 Issue 2

Tel: +44(0) 1803 407784
Fax: +44(0) 1803 407786
sales@sifamfo.com
www.sifamfo.com

Optical Specifications

Coupling Ratio	Grade	Signal Path					Tap Path				
		Insertion Loss _{1,2,6} (dB)		WDL ₃ (dB)	PDL ₄ (dB)	TDL ₅ (dB)	Insertion Loss _{1,2,6} (dB)		WDL ₃ (dB)	PDL ₄ (dB)	TDL ₅ (dB)
50%	H	2.80	3.30	0.20	0.20	0.16	2.80	3.30	0.20	0.20	0.16

1. Insertion loss over operating wavelength range (not including PDL, TDL or any connector losses),
2. In 2x2 couplers insertion loss is not specified for launch through second input port P4 (coloured blue)
3. Change in insertion loss over the operating wavelength range
4. Change in insertion loss over all input polarisation states at band centre wavelength
5. Change in insertion loss from -5 to 75°C
6. Excess Loss implied by design at 0.1dB

Parameter	Specification	Unit
Operating Wavelength Range ₁ C Band	1530-1570	nm
Return Loss/Directivity ₂	55	dB
Pigtail Tensile Load ₃	5	N
Optical power handling	4	W
Operating / Storage Temperature Range ₂	-10 to +70 / -25 to +85	°C
Environmental Qualification	Component design to 0.1FIT	Failures in billion hours

1. Return loss is the ratio of power launched to power reflected for port P1. Directivity for the 2x2 component is the ratio of power launched to P1 to the power reflected to P4. For 2x2 couplers return loss/directivity >60dB
2. For connectorised component, operating temperature range is -5 to +75°C.
3. Stripped fibre proof tested on rig to confirm strength maintained at virgin fibre level

Housing Option

Housing Code	Description	Dimensions (mm)	Pigtail
3	Regular	3.0 (Ø) x 50 (L)	Primary-coated fibre

SIFAM Fibre Optics Ltd
 Broomhill Way, Torquay
 Devon TQ2 7QL
 England



Certificate No. 0962231

Tel: +44(0) 1803 407784
 Fax: +44(0) 1803 407786
 sales@sifamfo.com
 www.sifamfo.com

Configuration



Ordering Code Information

Sample: **FFC-C231HB110** (C Band, 2% tap, regular housing, Hi-rel grade, SMF-28e fibre, 1m pigtail, no connector)

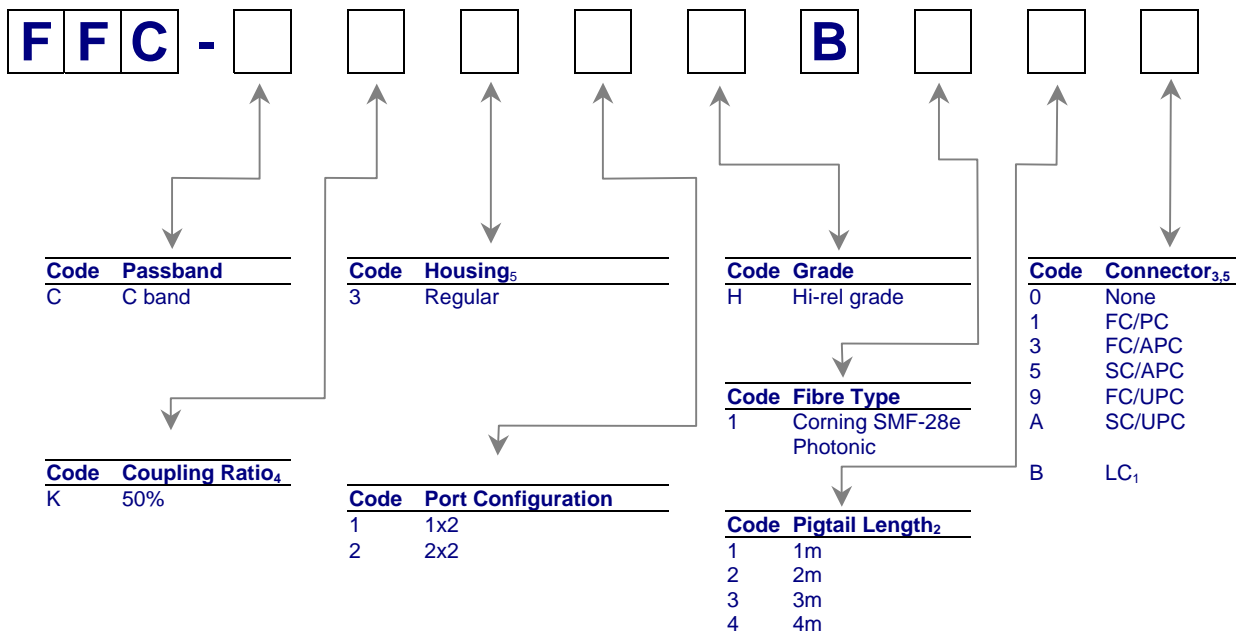

1. Not available for housing option 6.
 2. Minimum pigtail length. Further pigtail lengths available on request. Where connectorised, pigtail length is to connector end face.
 3. Insertion loss in specification table does not include connector losses.